

LU80, LU81, LU83 & LU84 Series Manual



The EchoSpan® is a general-purpose ultrasonic level transmitter that provides a loop powered 4-20 mA output. The 4-20 mA output can be used to provide the proportional level of liquid in any tank or vessel. The signal can be connected to any device that accepts a loop powered 4-20 mA signal, such as a PLC, SCADA, DCS, display, controller, etc.

NEW FEATURES

- Simple configuration with push button configuration
- Adjustable Loop Fail-Safe, Hold Last, Empty, Full, 21 mA, 22 mA
- Easy to reverse mA output, 4-20 mA to 20-4 mA
- Increased output filtering

TABLE OF CONTENTS

Specifications: 3

Dimensions: 3

Safety Precautions: 4

Components: 5

Features Guide: 5

Getting Started: 6

Getting Around the TOP-LEVEL MENU: 6

Descriptions: 7

Configuration: 9

Hot to Enter the TOP-LEVEL MENU: 9

How to configure UNITS: 9

How to configure the operational range using Height & Fill-H: 10

How to configure the operational range using Target Calibration: 11

How to select Fail-Safe (SAFE) current Output/ LOST:..... 12

Wiring: 13

Analog Output: 13

Common Wiring to Displays, Controllers & PLCs: 14

Installation: 16

Mounting Guide: 16

Installation in existing fitting: 16

Metal tanks: 16

Fitting Selection: 17

Appendix: 20

How to configure the DISPLAY: 20

How to reverse the current output (Rev mA): 20

SETUP: 21

Diagnostic (DIAG) parameters: 21

Reset: 22

Troubleshooting: 23

Warranty: 24

Range

LU80: 4" to 9.8' (10 cm to 3 m)	LU81: 8" to 18.0' (20 cm to 5.5 m)	LU83: 8" to 26.2' (20 cm to 8 m)	LU84: 8" to 32.8' (20 cm to 10 m)
------------------------------------	---------------------------------------	-------------------------------------	--------------------------------------

- Accuracy: ± 0.2% of range
- Resolution: LU80: 0.019" (0.5mm)
LU81: 0.039" (1mm)
LU83: 0.039" (1mm)
LU84: 0.078" (2 mm)
- Dead band: LU80: 4" (10cm)
LU81/83/84: 8" (20 cm)
- Beam width: LU80: 2" (5cm) dia.
LU81/83/84: 3" (7.6 cm)dia.
- Configuration: Push button
- Memory: Non-volatile
- Display type: LCD, 6-digit
- Display units: Inch, feet, cm, meters or percent
- Supply voltage: 14-28 VDC
- Loop resist.: 500 Ohms @ 24 VDC
- Signal output: 4-20 mA, two-wire
- Signal invert: 4-20 mA / 20-4 mA
- Signal fail-safe: 4mA, 20 mA, 21 mA, 22 mA, hold last
- Process temp.: F: -4° to 140°
C: -20° to 60°
- Temp. comp.: Automatic
- Ambient temp.: F: -4° to 140°
C: -20° to 60°
- Pressure: MWP = 30 PSI
- Enclosure rating: NEMA 4X (IP65)
- Encl. material: PC
- Encl. hardware: Brass and stainless
- Enclosure vent: Water tight membrane
- Conduit entrance: Dual, 1/2" NPT*
- Trans. material: PVDF, Viton
- Process mount: LU80: 1" NPT/1" G
LU81/83/84: 2" NPT/2" G
- Mount. gasket: Viton®
- Classification: General purpose
- Compliance: CE, RoHS

* If using the Flowline LM90-1001 (liquid tight fitting) on the 1/2" conduit, the cable minimum is 0.170" (4.3mm) and the maximum is 0.450" (11.4mm).

Side View
LU80 Series

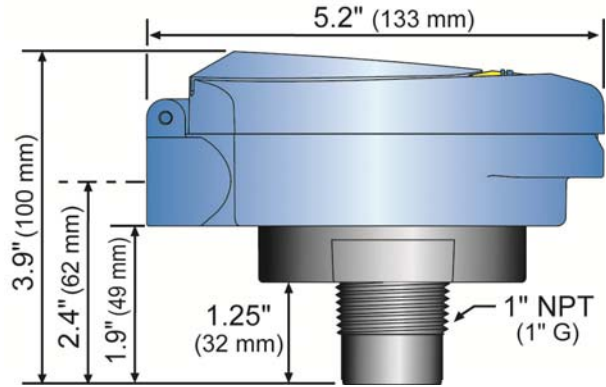

Side View
LU81, LU83 & LU84 Series

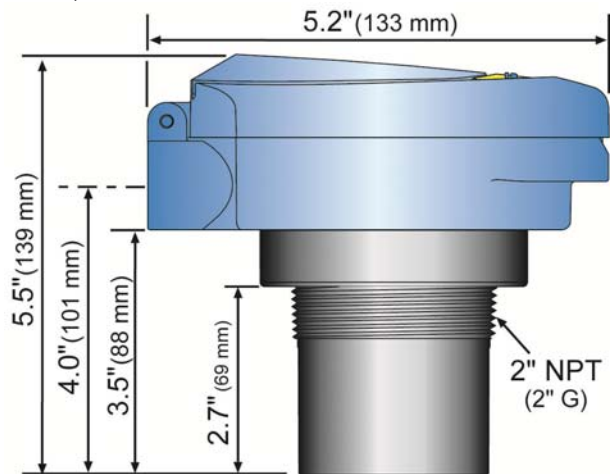

Top View
All Models

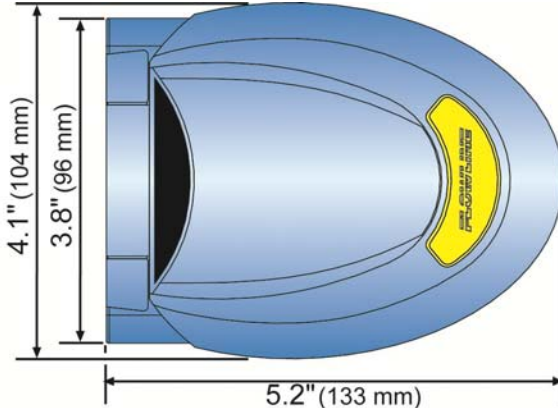

- ⚠ **About this Manual:** PLEASE READ THE ENTIRE MANUAL PRIOR TO INSTALLING OR USING THIS PRODUCT. This manual includes information on the EchoSpan® series Ultrasonic Level Transmitter from FLOWLINE. Please refer to the part number located on the switch label to verify the exact model configuration, which you have purchased.
- ⚠ **User's Responsibility for Safety:** Flowline manufactures a broad range of level sensing technologies. While each of these sensors is designed to operate in a wide variety of applications, it is the user's responsibility to select a sensor model that is appropriate for the application, install it properly, perform tests of the installed system, and maintain all components. The failure to do so could result in property damage or serious injury.
- ⚠ **Proper Installation and Handling:** Only professional staff should install and/or repair this product. Install the sensor with the included Viton gasket and never over tighten the sensor within the fitting. Always check for leaks prior to system start-up.
- ⚠ **Wiring and Electrical:** A supply voltage of 12 to 28 VDC is used to power the EchoSpan®. Electrical wiring of the transmitter should be performed in accordance with all applicable national, state, and local codes.
- ⚠ **Material Compatibility:** The enclosure is made of Polycarbonate (PC). The transducer is made of Polyvinylidene Fluoride (PVDF). Make sure that the model, which you have selected, is chemically compatible with the application media.
- ⚠ **Enclosure:** While the sensor housing is liquid-resistant the EchoSpan® is not designed to be operational when immersed. It should be mounted in such a way that the enclosure and transducer do not come into contact with the application media under normal operational conditions.

The enclosure has a flip cover with dual 1/2" NPT female conduit ports and an internal terminal strip for wiring. To open the enclosure, you will need a small flat-headed screwdriver. Loosen the locking screw located at the top front of the enclosure. Rotate the hinged cover up for 135° access to the faceplate and terminal strips. Before closing the enclosure, make sure that the enclosure gasket is properly seated, and that any conduit fittings, cable connectors or plugs are installed correctly and sealed.

Note: If using the Flowline LM90-1001 (liquid tight fitting) on the 1/2" conduit, the cable minimum is 0.170" (4.3mm) and the maximum is 0.450" (11.4mm).

- ⚠ **Handling Static-Sensitive Circuits/Devices:** When handling the transmitter, the technician should follow these guidelines to reduce any possible electrostatic charge build-up on the technician's body and the electronic part.
 1. Always touch a known good ground source before handling the part. This should be repeated while handling the part and more frequently after sitting down from a standing position, sliding across the seat or walking a distance.
 2. Avoid touching electrical terminals of the part unless making connections.
 3. DO NOT open the unit cover until it is time to calibrate.
- ⚠ **Warning:** Always use the Viton gasket when installing the EchoSpan®, and make sure that all electrical wiring of the switch is in accordance with applicable codes.

Make a Fail-Safe System: Design a fail-safe system that accommodates the possibility of switch and/or power failure. FLOWLINE recommends the use of redundant backup systems and alarms in addition to the primary system.

Flammable, Explosive or Hazardous Applications: *EchoSpan® should not be used within classified hazardous environments.*

COMPONENTS:

EchoSpan® is offered in three different models. Depending on the model purchased, you may or may not have been shipped all the components shown below. You do however, need an EchoSpan® and Viton® gasket to configure, install and operate EchoSpan®.

P/N	Max. Range	Dead Band	Thread	Enclosure
LU80-5101 LU80-5161	9.8' (3m)	4" (10cm)	1" NPT 1" G	Type 4X
LU81-5101 LU81-5161	18.0' (5.5m)	8" (20cm)	2" NPT 2" G	Type 4X
LU83-5101 LU83-5161	26.2' (8m)	8" (20cm)	2" NPT 2" G	Type 4X
LU84-5101 LU85-5161	32.8' (10m)	8" (20cm)	2" NPT 2" G	Type 4X

- Viton Gasket
 - Part #220128 – for LU80 series only
 - Part #220129 – for LU81, LU83 and LU84 series
- QUICK START GUIDE

FEATURE GUIDE

FEATURE	ACCESS BY
Easy to use TOP-LEVEL MENU	Press and hold <i>SELECT</i> key (approximately 5 seconds) until MENU is displayed. The items in the TOP-LEVEL MENU will rotate through display, press <i>SELECT</i> to change an item.
Many UNITS of measurement.	In the TOP-LEVEL MENU , press <i>SELECT</i> when UNITS is displayed, then select INCHES , CM (centimeter), FEET , METERS or PERCNT .
No cumbersome measure required. Set point distances are relative to the tank bottom.	In TOP-LEVEL MENU , select TANK and set the HEIGHT of the tank from the transducer face to the bottom of the tank. Set the Fill Height (FILL-H) to the maximum fill height of the liquid from the bottom of the tank. All of the set points are from the bottom of the tank up.
Optional Target Calibration	Use this feature if the tank liquid level is at an empty or full volume. This feature will accept the current liquid level as either empty (TG CAL EMPTY) or full (TG CAL FULL).
Fail-Safety	Use the SAFE function to preset the output to either Empty (4 mA), Full (20 mA , 21 mA or 22 mA) or Hold Last Value in case the transmitter loses it's signal (LOST).

EchoSpan® can be configured before installation. The transmitter features non-volatile memory, so the set points configured before installation will not be lost when the switch is powered down. To start, all you need is the following information:

- Basic Tank Information
 - **HEIGHT** – Distance from the transducer face to the bottom of the tank.
 - **FILL-H** – Maximum fill height of the liquid from the bottom of the tank.
- Set Points (optional):
 - If the sensor is to be used to provide feedback to the control of pumps, valves or alarms, you will need the measured distance from the bottom of the tank to each of the device's set point(s).
- Power:
 - Provide input power to the EchoSpan®

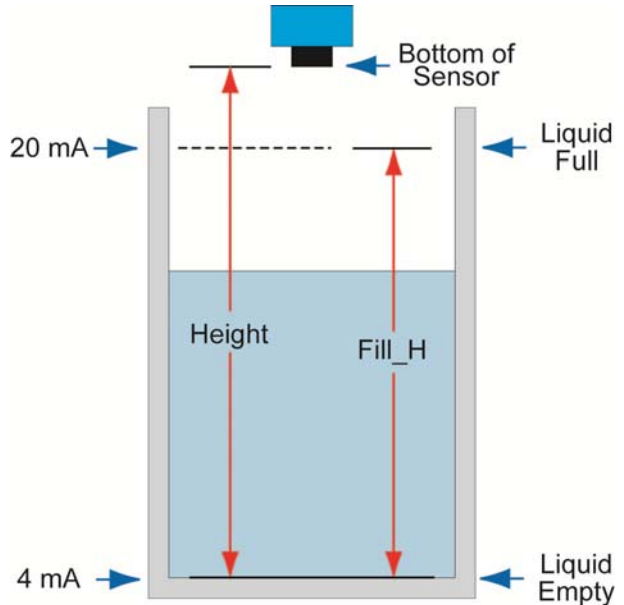

Note: The **HEIGHT** and Fill-Height (**FILL-H**) settings also determine the 4 to 20 mA current span. The **HEIGHT** setting determines the 4mA position and the **FILL-H** setting determines the 20 mA position.

Getting Around the TOP-LEVEL MENU: EchoSpan® is configured by the use of three push buttons (UP, DOWN and SELECT) and a LCD display.

As a lockout feature, the buttons are inactive until the SELECT button is held down for 5 seconds, and then the display will begin to scroll through the top level of the configuration menu.



TOP-LEVEL MENU

- The TOP-LEVEL MENU will continue to scroll through the items listed to the right until the SELECT button is pressed.
- To return to the Normal / Operational mode of EchoSpan®, press SELECT while **RUN** appears in the display.

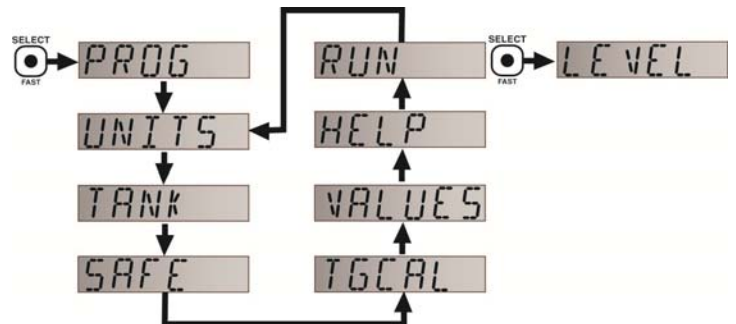

TOP-LEVEL MENU DESCRIPTIONS

- **UNITS** – Allows end user to select the units for configuration and operation. Additional function allows the display to show liquid level or air gap.
 - Select between **INCHES**, **CM** (Centimeters), **FEET**, **METERS** or **PERCNT** (Percent).
 - Select between **AIR** or **LIQUID** for the display.
 - **AIR** configures display to show the air gap in the tank.
 - **LIQUID** (factory default) configures display to show the level of liquid in the tank.
 - This function does not influence the current output, just the display on the sensor.
 - Press **EXIT** to return to the TOP-LEVEL MENU.

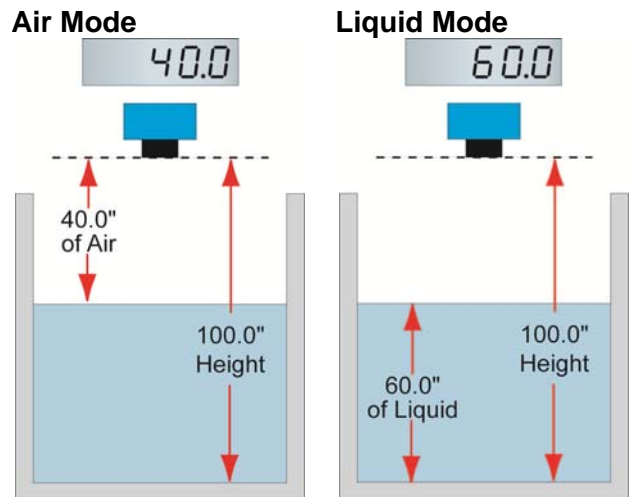

Note: Flowline recommends that when selecting **PERCNT**, configure the **HEIGHT** and **FILL-H** settings before selecting **PERCNT** in order to span the EchoSpan[®] for your application requirements.

Note: if **UNITS** is set to **PERCENT**, then **TANK** will not appear. To view **TANK**, set **UNITS** to any of the following: **INCHES**, **CM** (Centimeters), **FEET** or **METERS**.

- **TANK** – Allows the end user to configure the operational range for the switch as well as the 4-20 mA output signal. Additional function allows the output current to be reversed.
 - **HEIGHT** – Distance from the transducer face to the bottom of the tank.
 - **FILL-H** – Maximum fill height of the liquid from the bottom of the tank.
 - **Note:** The 4 and 20 mA points are set by setting these two points.
 - Fill-H sets the 20 mA set point and Height sets the 4 mA set point. This is the factory default.
 - Use the REV MA setting to reverse the 4 and 20 mA set points.
 - **REV MA** – Allows the current output to be reversed.
 - In NORM mode (factory default), 4mA is at bottom and 20mA is at top of the tank.
 - In REV mode, 4mA is at top and 20mA is at bottom of the tank.
 - Press **EXIT** to return to the TOP-LEVEL MENU.

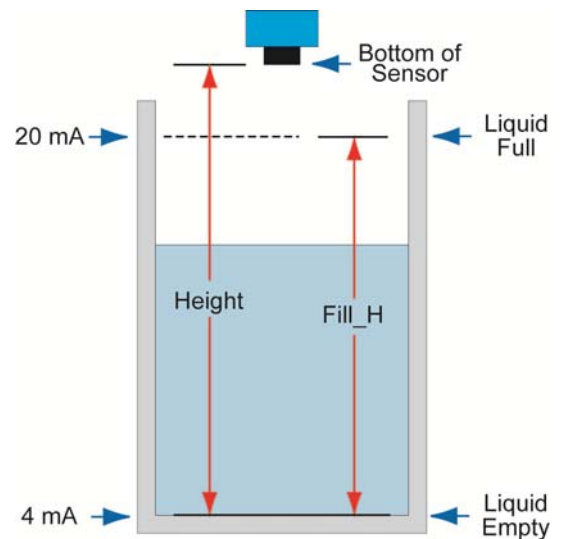

- **SAFE** – In the event the sensor does not receive an echo, the Fail-Safe Current Output or LOST setting can be set to output a current of 4mA, 21mA or Hold (last known value).
 - **22mA** – Overfill fail-safe setting.
 - **21mA** – Overfill fail-safe setting.
 - **20mA** – Full fail-safe setting.
 - **4mA** – Empty fail-safe setting.
 - **HOLD** – Keeps the current output at the last reading when fail-safe condition occurs.

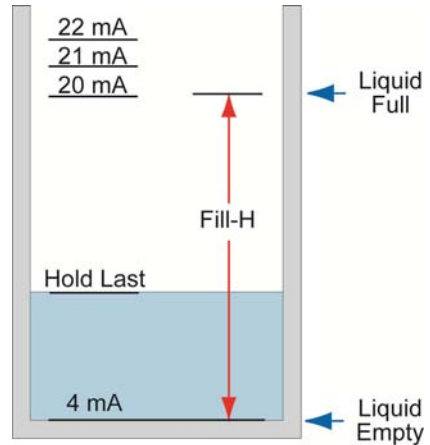

Note: During fail-safe, the display will read **LOST**.

- **TG CAL** – Target Calibration (allows for the sensor to accept as either **EMPTY** or **FULL** the liquid level at that moment. Liquid level must be at either the required **EMPTY** or **FULL** levels of liquid.

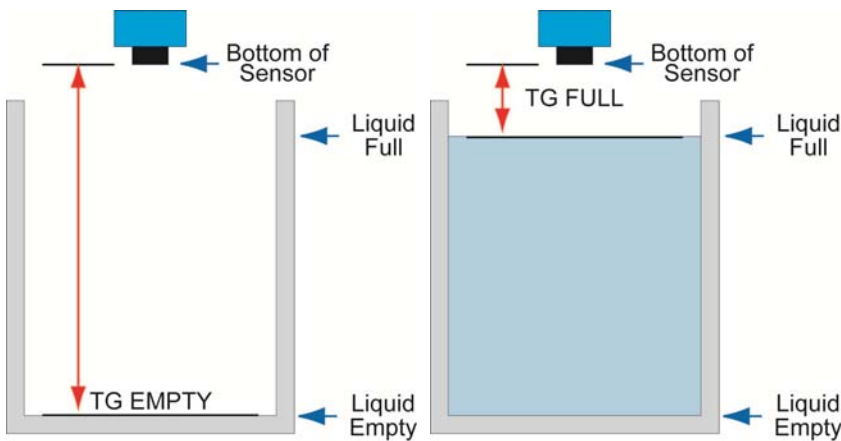

- **VALUES** – Provides setup information, a diagnostic to be used in conjunction with a Flowline Representative and the ability to reset the EchoSpan®.
 - **SETUP** – Will display the setting for all functions of EchoSpan®.
 - **DIAG** – This is a production test feature used by the factory to confirm operation. **This mode should only be used when supervised by a Flowline representative.**
 - **RESET** – Will reset the EchoSpan® back to its original factory setting.
- **HELP** – Provides information for contacting Flowline on-line.
- **RUN** – Returns the unit to normal measurement and control mode.

This section will take you through the key steps in the setup and configuration of EchoSpan®:

- 1) *Select the units for configuration.*
 - a. Determine the measurement units that will be used to configure the sensor.
- 2) *Measure the distance from the bottom of the tank (empty level) to the bottom of the sensor.*
 - a. Be sure to include the added height of installation fittings.
- 3) *Measure the distance from the bottom of the tank (empty level) to the full level of liquid.*
 - a. Take into account the dead band of the sensor.
- 4) *Determine the fail-safe output in the event of a LOST signal condition.*
 - a. Example: will the output over-ride a pump on or pump off status during a LOST signal condition.

HOW TO ENTER THE TOP-LEVEL MENU

1. Press and hold SELECT (approximately 5 seconds) until **MENU** is displayed.
2. The TOP-LEVEL MENU items will rotate through display.
3. Use SELECT to choose a MENU item.



HOW TO EXIT THE TOP-LEVEL MENU

In TOP-LEVEL MENU, press SELECT when **RUN** appears.

HOW TO CONFIGURE UNITS

1. In the TOP-LEVEL MENU mode, select **UNITS**.
2. Press SELECT to choose between **INCHES**, **CM** (centimeter), **FEET**, **METERS** or **PERCNT** (percent).
3. Select EXIT to return to the TOP-LEVEL MENU.

Note: Reading the level of liquid in Percent

- Flowline recommends that when selecting **PERCNT**, configure the **HEIGHT** and **FILL_H** settings before selecting **PERCNT** in order to span the EchoSpan® for your application requirements.
- When in **PERCNT**, the operational span will be based upon the last **TANK** settings, 100% will occur at the **FILL-H** level and 0 percent at the bottom of the tank.
- When **PERCNT** is selected, the **TANK** settings (**HEIGHT** and **FILL_H**) will be disabled. They will remain disabled until a different unit of measurement is selected under **UNITS**.

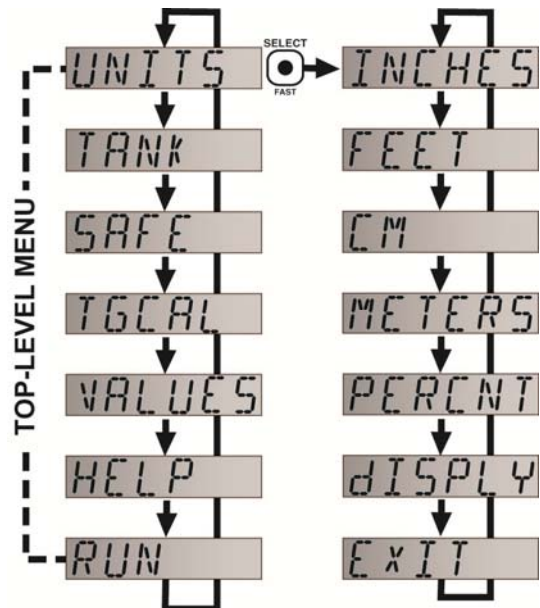

Note: EchoSpan® will adjust the display when measurement units are changed under **UNITS**. Example: If you are in inches and the display reads 60.0, the display will change to 5.00 when feet is selected as the unit of measurement.

HOW TO CONFIGURE THE OPERATIONAL RANGE OF ECHOSPAN® USING SENSOR HEIGHT AND FILL-HEIGHT

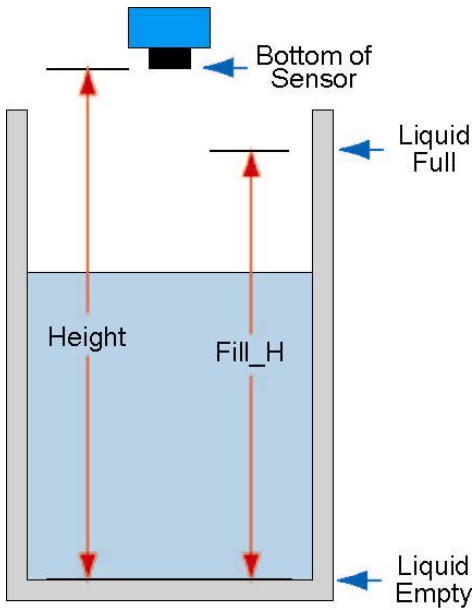

Before starting, take two measurements. 1) Measure the distance from the bottom of the sensor (transducer face) to the bottom of the tank. This will be the HEIGHT setting. 2) Measure the distance from the bottom of the tank to the Maximum Level of Liquid (Full). This will be the FILL-H setting.

1. In TOP-LEVEL MENU mode, select **TANK**.
2. Select **HEIGHT**.
3. Using the UP and DOWN buttons, set the **HEIGHT** of the tank (transducer face to the bottom of the tank).
4. To enter the value, press and hold SELECT for 2 seconds and release. **SAVED** will display.
5. When **FILL-H** appears, press SELECT.
6. Using the UP and DOWN buttons, set the Fill Height (**FILL-H**) of the tank (max. level of liquid to the bottom of the tank).
7. To enter the value, press and hold SELECT for 2 seconds and release. **SAVED** will display.
8. Select **EXIT** to return to TOP-LEVEL MENU.

Note: The **HEIGHT** and Fill-Height (**FILL-H**) settings also determine the 4 to 20 mA current span. The **HEIGHT** setting determines the 4mA position and the **FILL-H** setting determines the 20 mA position. To reverse the current output, use the **REV MA** function.

Note: To speed up the scrolling of the values on the display, hold down the SELECT button while holding down the UP or DOWN buttons.

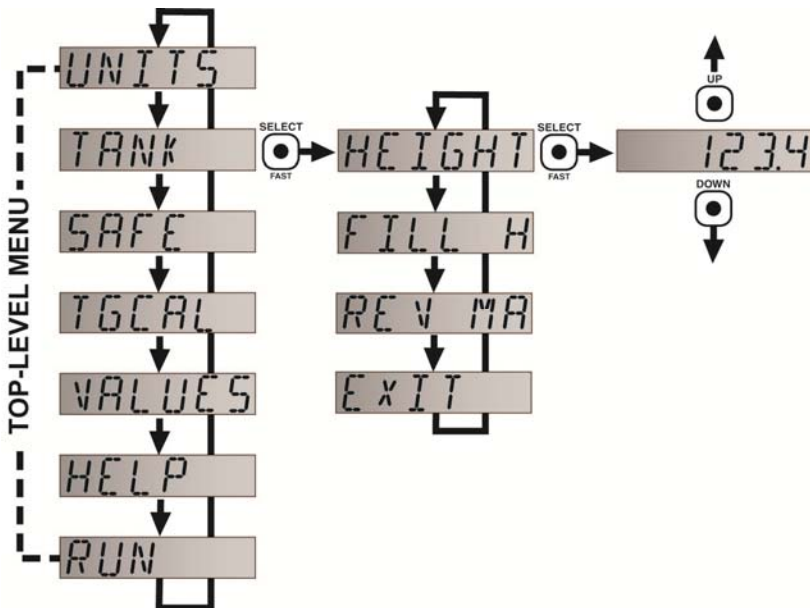

HOW TO CONFIGURE THE OPERATIONAL RANGE OF ECHOSPAN® USING TARGET CALIBRATION (TGCAL)

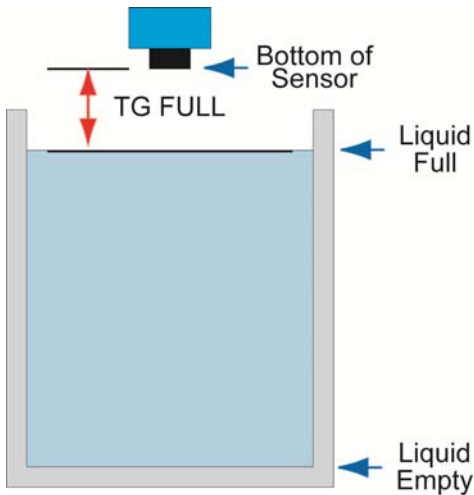
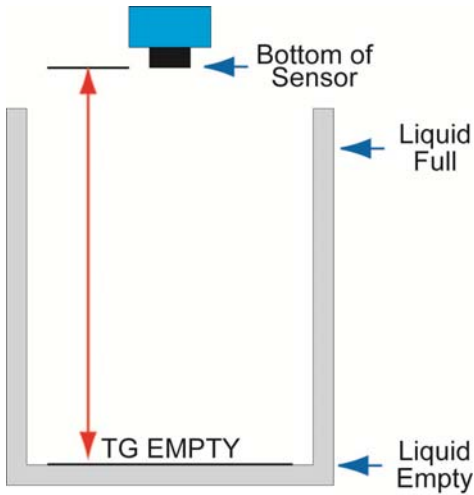

TG Cal is an alternative configuration method for setting the 4-20 mA current span within EchoSpan®. Use this method only if you are able to completely empty and/or fill the tank. TGCAL involves two settings, Empty and Full.

- **TG Cal (EMPTY)** requires the tank be empty when performing this function.
 - When performed, the function will take a sample reading and will use the distance measured as the empty setting.
- Likewise, **TG Cal (FULL)** requires the tank be full when performing this function.
 - When performed, the function will take a sample reading and will use the distance measured as the full setting.

Note: If this function is performed while the tank is not at empty or full, the scaling of the current output will be off.

1. In TOP-LEVEL MENU mode, select **TGCAL**.
2. Select **EMPTY** if the tank is empty or select **FULL** if the tank is full. **SAVED** will display.
3. Change the level to the other state (full or empty).
4. Select **EMPTY** if the tank is empty or select **FULL** if the tank is full. **SAVED** will display.
5. Select **EXIT** to return to TOP-LEVEL MENU.

Note: The Empty and Full settings determine the 4 to 20 mA current span. With **REV MA** set to **NORM**, empty sets 4mA and Full sets 20mA. With **REV MA** set to **INV**, empty sets 20mA and Full sets 4mA.

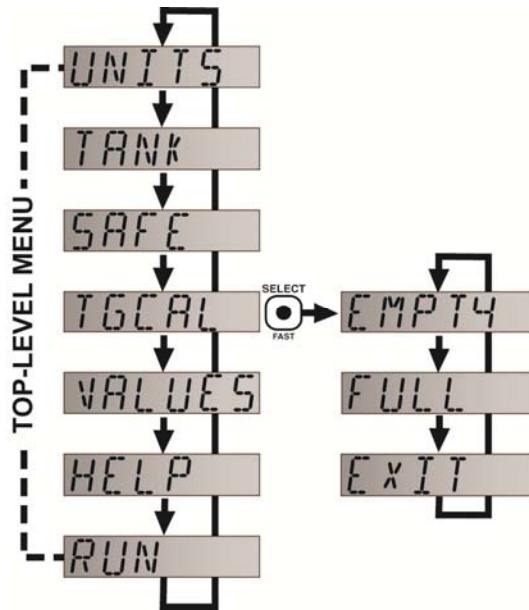

HOW TO SELECT FAIL-SAFE CURRENT OUTPUT / LOST:

In the event the sensor does not receive an echo, the Fail-Safe Current Output or **LOST** setting can be set to output a current of **4mA**, **20mA**, **21mA**, **22mA** or **Hold** (last known value). During fail-safe, the display will read **LOST**.

1. In TOP-LEVEL MENU mode, select **SAFE**.
2. Select **4mA**, **20mA**, **21mA**, **22mA** or **HOLD**.
3. Select **EXIT** to return to TOP-LEVEL MENU.

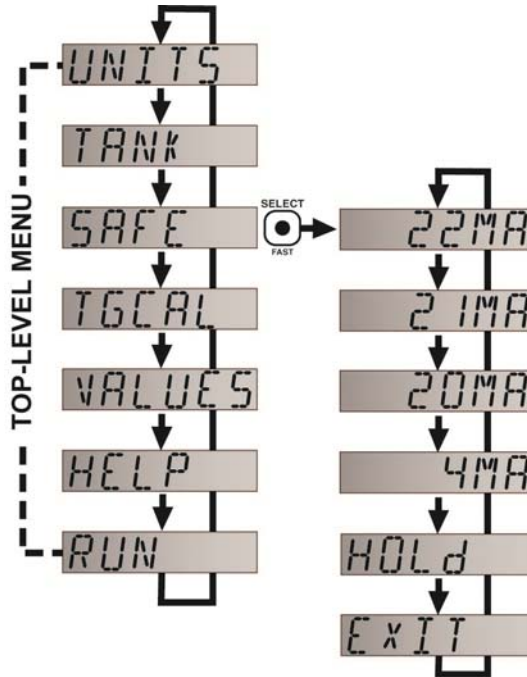
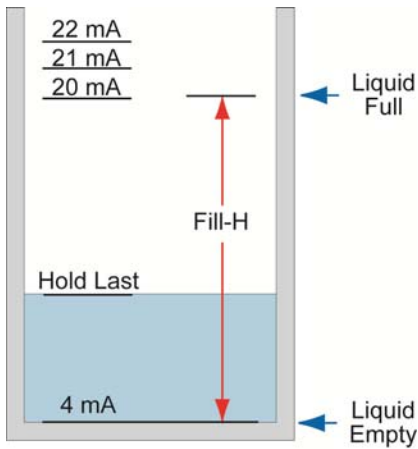

ANALOG OUTPUT (4-20 MA):

The analog output of the EchoSpan® is a loop powered 4-20 mA control circuit. The typical way to use this feature is to connect a positive supply to the (+) input and to sense the current flow out of the (-) output with a sampling resistor as shown in the following diagram.

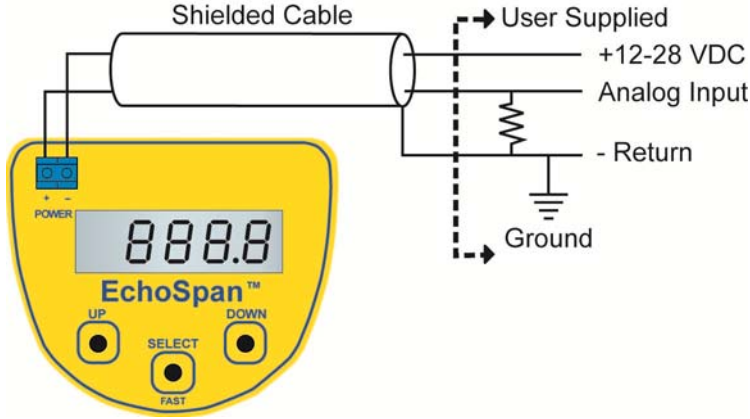

The cabling should be a shielded twisted pair to minimize EMI interference. Typically 20 to 24 gauge wire is used in this application.

GENERAL NOTES FOR ELECTRICAL CONNECTIONS, USAGE AND SAFETY:

- Where personal safety or significant property damage can occur due to a spill, the installation must have a redundant backup safety system installed.
- Wiring should always be completed by a licensed electrician.
- When using a liquid tight fitting (cord grip), make sure the cable meets the fittings specification.
 - Example: The LM90-1001 nylon liquid tight fitting has a cable minimum of 0.170" (4.3mm) and cable maximum of 0.450" (11.4mm)
- Protect the sensor from excessive electrical spikes by isolating the power, whenever possible.
- Supply voltage should never exceed 28 VDC.
- The sensor materials must be chemically compatible with the liquids to be measured.
- Design a fail-safe system for possible sensor and/or power failure.
- **Never use the sensor in environments classified as hazardous.**

VOLTAGE OUTPUT:

EchoSpan® can be used as a 0 to 5 or 0 to 10 VDC output device. A resistor will need to be added to the circuit to enable a voltage output (refer to the wiring diagram below).

- 0-5 VDC output
 - Add a 250 Ohm resistor
 - Actual output will be 0.8 to 5 VDC
- 0-10 VDC output
 - Add a 500 Ohm resistor
 - Actual output will be 2 to 10 VDC

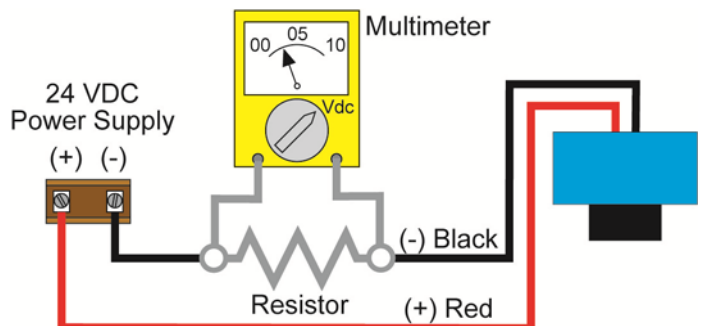

COMMON WIRING TO DISPLAY, CONTROLLERS & PLC'S

Below is a quick review of wiring the EchoSpan® to common display, controllers and PLC's.

**DataView™ LI55 Series
Level Controller**

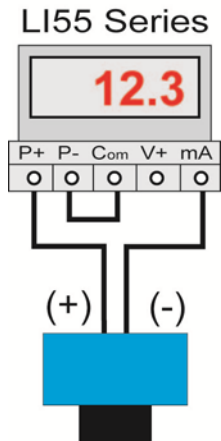

**Commander™ LI90 Series
Multi-Tank Level Controller**

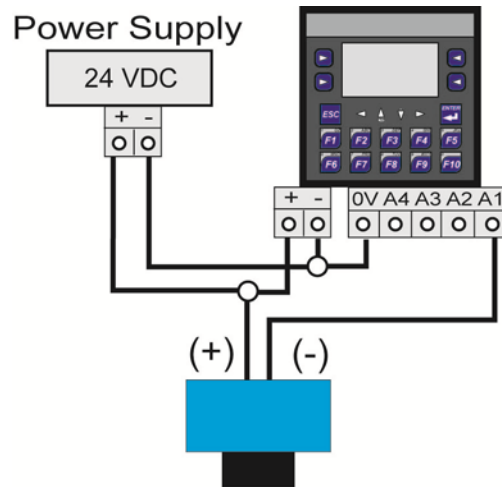

**DataLoop™ LI25 Series
Level Indicator
without the backlight**

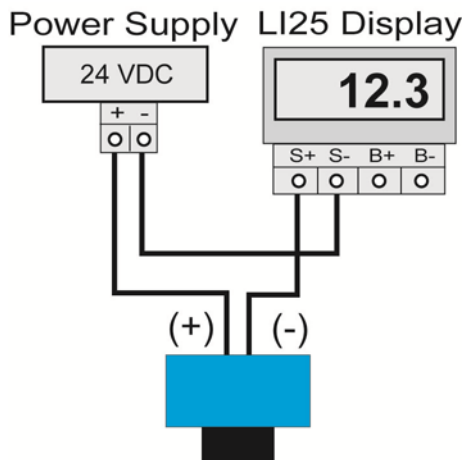

**DataLoop™ LI25 Series
Level Indicator
with the backlight**

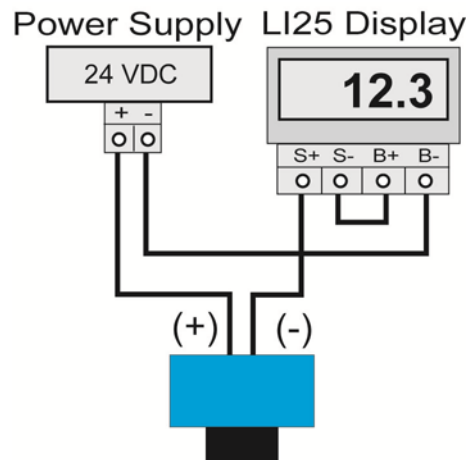

**DataPoint™ LC52 Series
Level Controller
JWA mode (Factory Setting)**

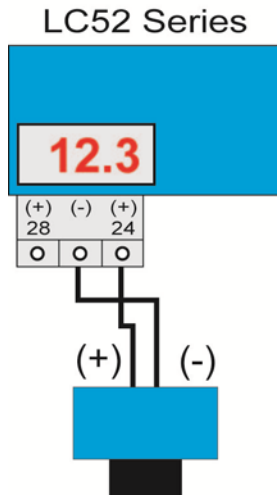

**DataPoint™ LC52 Series
Level Controller
JWB mode**

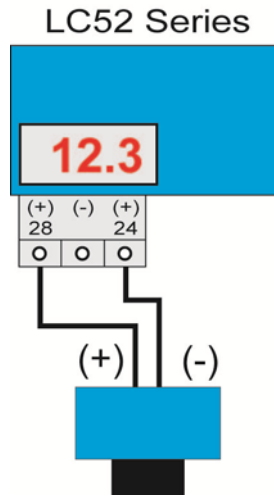

**Generic Loop
Powered Display**

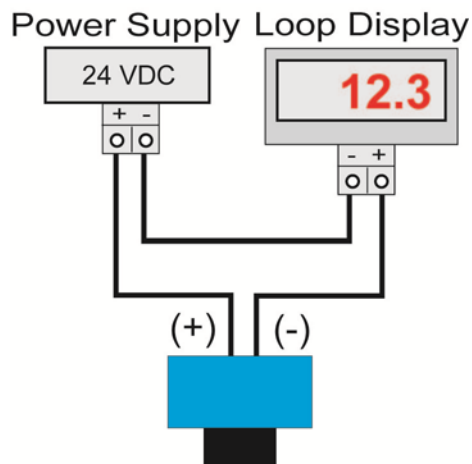

Generic PLC

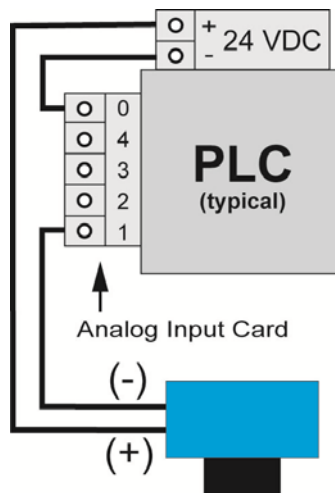

EchoSpan® should always be mounted perpendicular to the liquid surface and installed using the provided Viton mounting gasket. Make sure that the fitting and transmitter threads are not damaged or worn. Always *hand-tighten* the transmitter within the fitting. Perform an installed leak test under normal process conditions prior to system start up. **Note:** The preferred mounting fitting for the LU80 series is the LM52-1400 (2" thread x 1" thread) reducer bushing.

MOUNTING GUIDE

1. Do not mount at an angle
2. Liquid should never enter the dead band
3. Side Wall:
 - a. Mount at least 3" from the side wall
 - b. For LU80 Series - mount at least 2" from the side wall
4. Do not mount where obstacles will intrude on sensor's beam width
 - a. For LU80 Series - mount at least 2" from the side wall
 - b. For LU81, LU83 & LU84 Series - mount at least 3" from the side wall
5. Do not mount in a vacuum
6. Avoid mounting in the center of a dome top tank.
7. In cone bottom tank, position the sensor over the deepest part of the tank.

INSTALLATION IN EXISTING FITTINGS:

If the existing fitting is larger than the threads of the EchoSpan®, select a reducer bushing such as the LM52-1400 (2" thread x 1" thread) or LM52-2400 (3" thread x 2" thread).



LM52-1400



LM52-2400

METAL TANKS (LU80 SERIES)

Flowline ultrasonic transmitters have been optimized for use in non-metallic fittings.

1. For best performance, avoid the use of metallic fittings.
 - a. Use a plastic 2" x 1" reducer bushing, such as the LM52-1400 or a plastic 1" flange, such as the LM52-1850 for metallic tanks.
2. While installations directly into a 1" metal fitting are not recommended, acceptable results may be obtained if the 1" fitting is a half coupling in form and the outer diameter of the coupling is tightly wrapped in vinyl tape to dampen vibrations.

<p><i>Do not install at angle relative to the liquid.</i></p>	
<p><i>Do not install within 3" of tank sidewall.</i></p>	
<p><i>Do not install with objects in the beam.</i></p>	
<p><i>Do not install in applications with vacuum.</i></p>	

FITTING SELECTION:

Check the part number to determine the required fitting mount size and thread type. EchoSpan® is commonly installed in tank adapters, flanges, brackets or standpipes. **Note:** Always include the gasket when installing the EchoSpan®.

1. **Tank Adapter:** Select a tank adapter fitting, such as the LM52-1890 for the LU80 series or the LM52-2890 for the LU81, LU83 & LU84 series.
 - a. For best results, select a 2" tank adapter and add a reducer bushing such as the LM52-1400, thread x thread, reducer bushing.
 - b. Avoid tank adapter (thread x thread) styles and/or pipe stops forward of the installed transducer.
 - c. Always mount the tank adapter so the majority of fitting is outside the tank.
 - i. **Note:** Never mount the tank adapter upside down or where the bulk of the material is inside the tank.

**2" Tank Adapter
Socket x Thread
(LM52-2890)**



**Tank Adapter
w/ 2"x1" Reducer Bushing
(LM52-2890 w/LM52-1800)**



**Tank Adapter
Thread x Thread**



Do not use thread x thread

2. **Riser:** Installations with tall, narrow risers can impede the acoustic signal.
 - a. **Core Out Concrete:** Applications where a tank with a concrete ceiling that has been cored out can also be considered as a riser type application. In these applications follow a 2:1 ratio (Inner Diameter to Core Height) for the diameter of the core.
 - a. **LU81, LU83 & LU84 Series:** 2" (5 cm) diameter risers should be no taller than 5" (12.7 cm). Larger diameter risers should be no taller than 12" (30.5 cm).
 - b. **LU80 Series:**

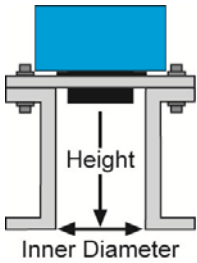
	Riser Specifications	
	Inner Diameter	Maximum Height
	2" (5cm)	3" (7.6cm)
	4" (10cm)	8" (20cm)
	6" (15cm)	12" (30cm)



Note: If attempting to raise the sensor above the top of the tank to allow for a higher fill capacity, avoid the use of tall and narrow risers. The example to the left exceeds the dimensions listed in the **Riser Specifications** chart. Use a larger tank adapter which takes into account the **Riser Specifications**.

Note: Do not exceed the dimensions listed above.

3. **Flange (LU80 series):** If installing on a flange, select a flange with a thread that is above the plane of the flange, such as the LM52-1850.
 - a. Avoid the use of blind flanges with tapped threads or flanges where the threads are even with the plane of the flange, such as the Banjo 1" Poly ANSI Flange (series AF100).
 - b. Use a flange with a 2" thread and add a 2" to 1" reducer bushing to complete the installation.
 - c. *The LU81, LU83 & LU84 series works well with Flange installations*



4. **Side Mount Bracket:** For installations in open tanks and sumps, use the LM50 series side mount bracket.
 - a. For the LU80 series, order the LM50-1001-1, which includes a 2"x 1" Reducer Bushing.
 - b. For the LU81, LU83 & LU84, series, order the LM50-1001 side mount bracket.

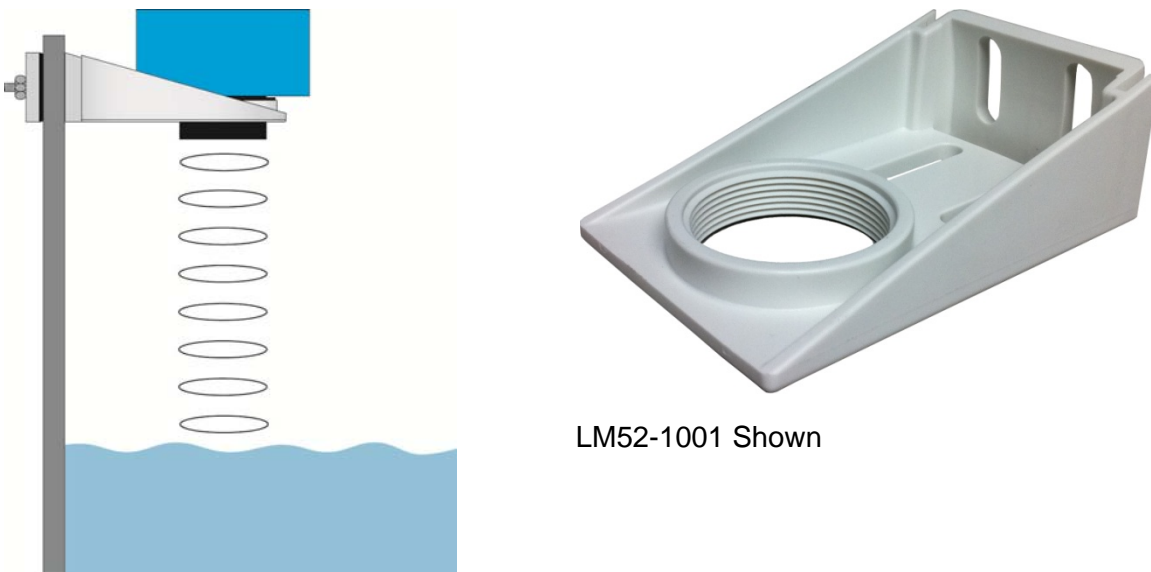

LM52-1001 Shown

Note: *The Side Mount Bracket (LM50 series) is not designed for use with stand pipes or as a method to secure stand pipes. There are too few threads to properly hold the sensor and the stand pipe.*

5. **Stand Pipe:** A standpipe may be used to dampen turbulence or when foam is present in the application.

- a) Pipe can be made of any material.
- b) Select a minimum 3" ID pipe for the stand pipe.
 - i) A 2" pipe (minimum pipe size) is usable with the LU80 series.
 - ii) Pipes larger than 3" can also be used.
- c) Use a coupling and reducer bushing to attach the EchoSpan® to the pipe.
 - i) With the LU80 series, be sure to use a plastic reducing bushing such as LM52-1400 2" Thread x 1" Thread fitting or the LM52-1410 2" Slip x 1" Thread fitting.
 - ii) For the LU81, LU83 & LU84 series, use a reducer bushing such as LM52-2400 (3" Thread x 2" Thread) fitting or the LM52-2410 (3" Slip x 2" Thread) fitting.
- d) The pipe length should run the measurement span and the bottom of the pipe should remain submerged at all times to prevent foam from entering the pipe.

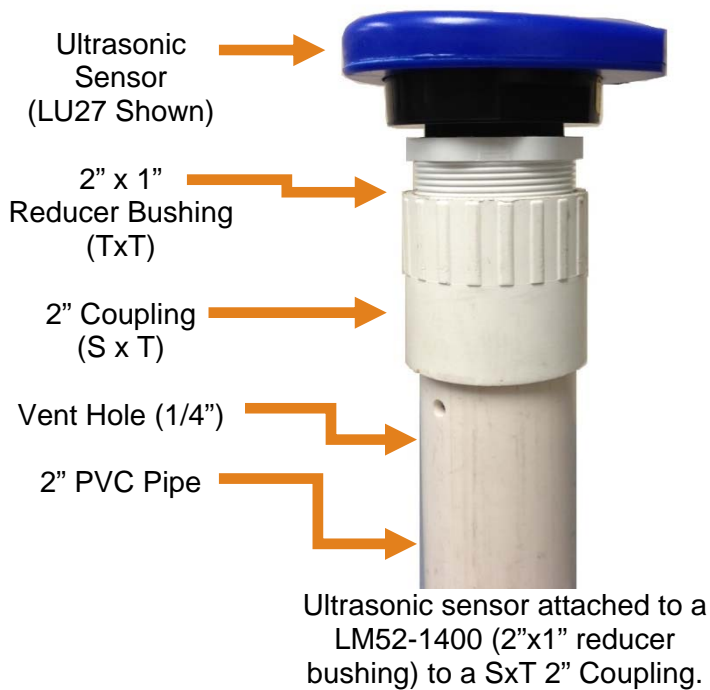
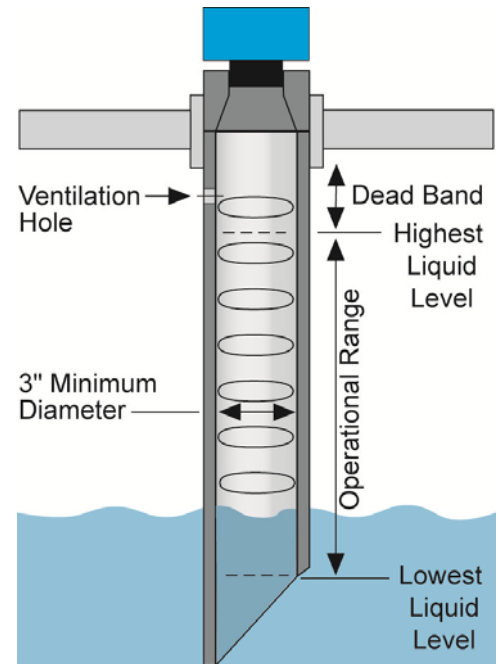

Avoid the use of a tee within the stand pipe. A tee can create false signals which will interfere with the sensor's performance.

AIR GAP VS. LIQUID LEVEL (HOW TO SELECT THE DISPLAY SETTING):

The display can be made to display either the height of liquid in the tank (**LIQUID** mode) or the amount of air in the tank (**AIR** mode). This function does not influence the current output, just the display on the sensor.

1. In TOP-LEVEL MENU mode, select **UNITS**.
2. Select **DISPLAY**.
3. Select **LIQUID** or **AIR**. **SAVED** will display.
4. Select **EXIT** to return to TOP-LEVEL MENU.

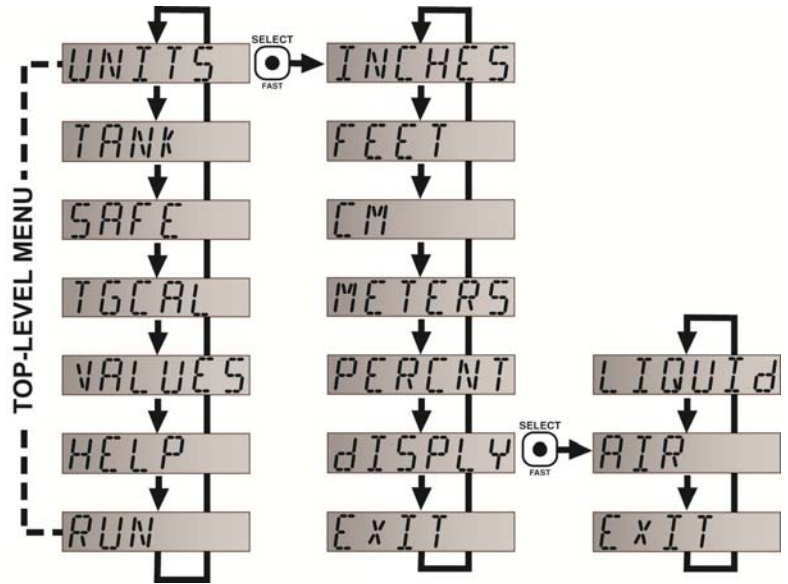
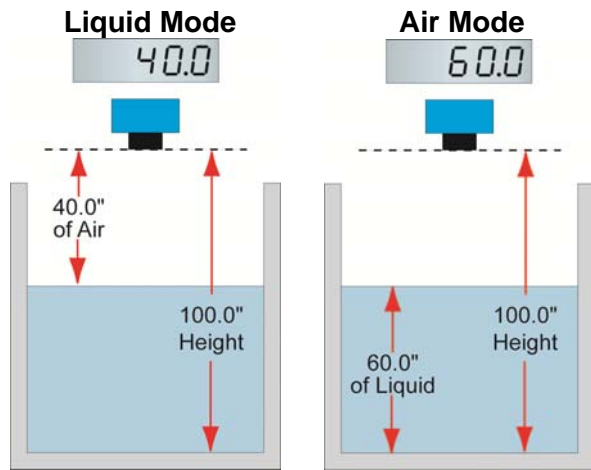

HOW TO REVERSE THE CURRENT OUTPUT:

The factory setting for EchoSpan® has 4mA set to the bottom of the tank and 20mA at the top. If the application requires this output to be reversed (20mA at bottom and 4mA at top), then use the REV MA setting to reverse the current output.

- With **REV MA** set to **NORM** (factory default), 4mA will be at the bottom and 20 mA at the top of the tank.
- With **REV MA** set to **REV**, 20mA will be at the bottom and 4mA at the top of the tank.

1. In TOP-LEVEL MENU mode, select **TANK**.
2. Select **REV MA**.
3. Select **NORM** or **REV**. **SAVED** will display.
4. Select **EXIT** to return to TOP-LEVEL MENU.

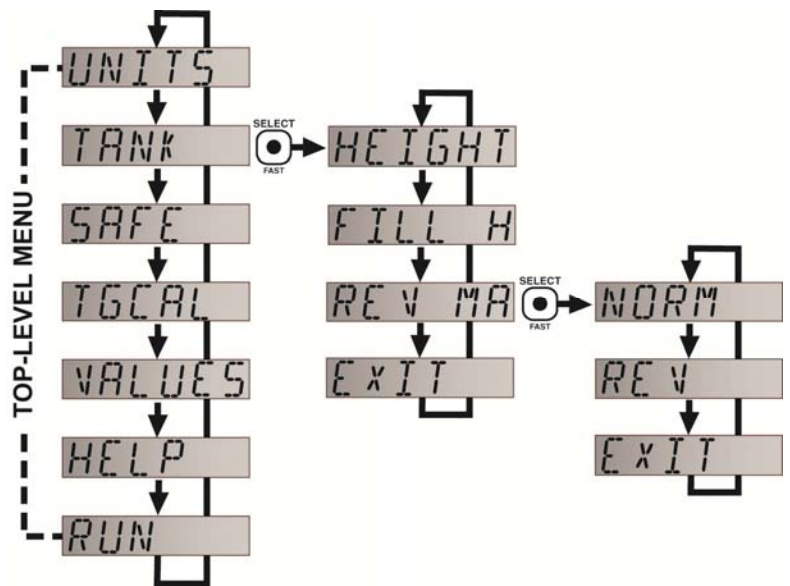
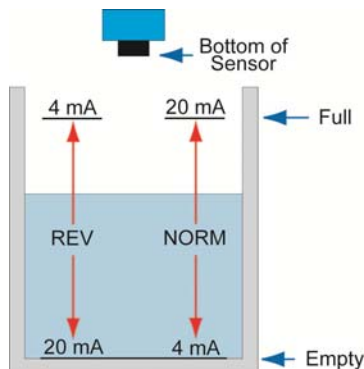

SETUP:

Will display the configuration settings for EchoSpan®.

1. In TOP-LEVEL MENU mode, select **VALUES**.
2. Select **SETUP**.
3. Setup will list the following information:
 - a. **UNITS**,
 - b. **DISPLY**,
 - c. **REV MA**,
 - d. **SAFE**,
 - e. **HEIGHT**,
 - f. **FILL-H**
4. Select **EXIT** to return to TOP-LEVEL MENU.

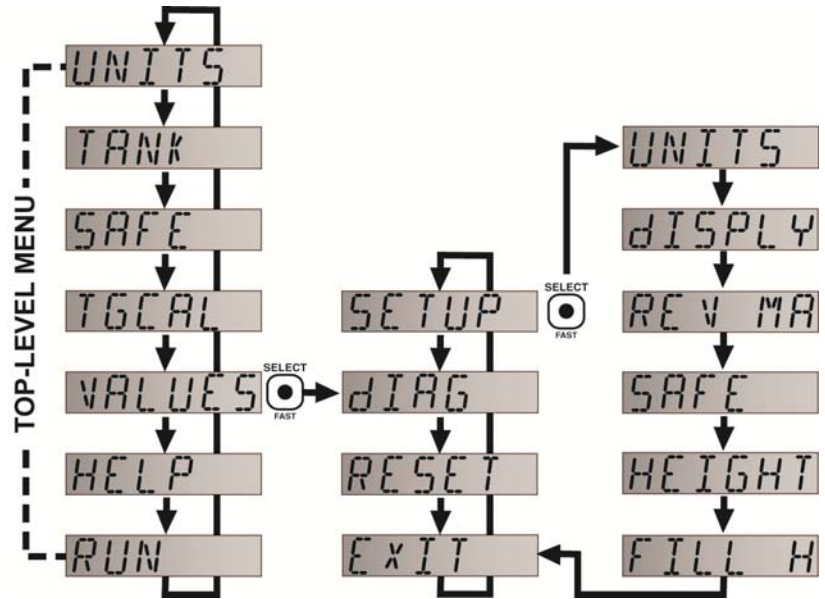

DIAGNOSTIC (DIAG) PARAMETERS:

This mode runs diagnostic tests that confirm operation of EchoSpan®. This is a production test feature used by the factory to confirm operation.

1. In TOP-LEVEL MENU, select **VALUES**.
2. Select **DIAG**.
3. DIAG will list the following settings:
 - a. **RANGE**
 - b. **TEMP**
 - c. **ECHO**
 - d. **POWER**
 - e. **MOUNT**
 - f. **VER**
4. Select **EXIT** to return to TOP-LEVEL MENU.

Note: This mode should only be used when supervised by a Flowline representative.

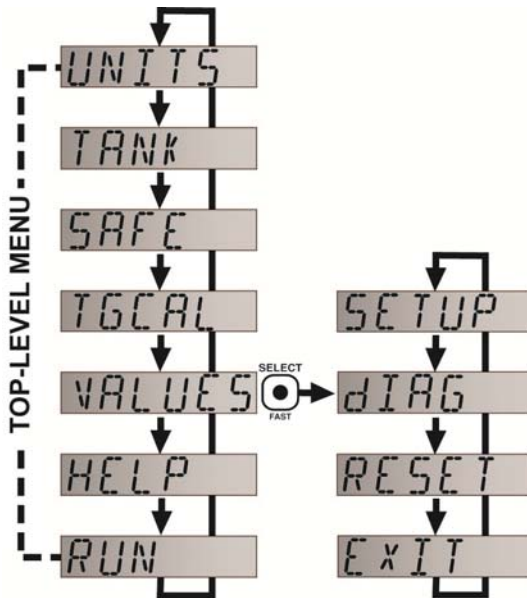

RESET:

EchoSpan® enables the end user to reset the entire configuration back to the original factory settings.

1. In TOP-LEVEL MENU mode, select **VALUES**.
2. Select **RESET**.
3. Select **YES**.
 - a. To cancel the reset, Select **NO**.
4. Select **EXIT** to return to TOP-LEVEL MENU.

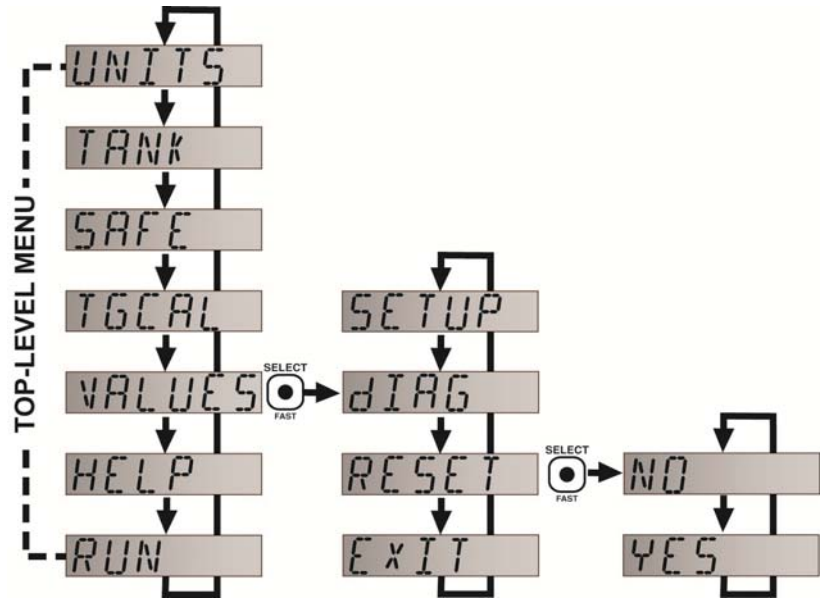

FACTORY SETTINGS:

EchoSpan®	Sensor Height	Fill-Height
LU80 Series	118.1" (300 cm)	114.1" (290 cm)
LU81 Series	216.5" (550 cm)	208.5" (530 cm)
LU83 Series	314.9" (800 cm)	307.1" (780 cm)
LU84 Series	393.7" (1000 cm)	381.9" (970 cm)

USER SETTINGS:

Fill out the chart below and keep as a record of your configuration.

Tank

Height =	Fill-H =
Norm	Reverse

Units

Inches	Feet	cm	Meter	Percent
Air		Liquid		

Safe

22mA	21 mA	20mA	Hold Last	4mA
------	-------	------	-----------	-----

TROUBLESHOOTING:

PROBLEM	SOLUTION
TANK does not appear on the main menu:	Units function is set for PERCNT on EchoSpan®: When Units is set for PERCNT , the TANK function is disabled. To re-enable TANK , change units to INCHES, CM, FEET or METERS .
Display shows FULL :	Level of liquid is above the FILL-H setting: Check the FILL-H setting, making sure the FILL-H setting is high enough so the level of liquid is below the FILL-H setting. The FILL-H setting is the distance from the bottom of the tank to the Full level of liquid.
Display shows EMPTY :	Level of liquid is beyond the HEIGHT setting: Check the HEIGHT setting, making sure the HEIGHT setting is low enough so the level of liquid is above the HEIGHT setting.
Display shows WARMUP :	Typically occurs when power is being applied to transmitter. Indicates a weak power supply, bad wire connections or the sensor is out of the operational range.
Display shows LOST :	Sensor is in a Fail-Safe state. The return sound pulses are not reaching the transducer. First, cycle power off and on, waiting 5 seconds between the off and on states. If problem persists, check the installation fitting against the Installation instructions in the manual.
Display is opposite of the measured value:	Check the DISPLAY setting. AIR mode indicates the distance from the liquid to the sensor. LIQUID mode indicates the height of liquid in the tank. Change the DISPLAY mode from AIR to LIQUID or vice versa to correct.
Transmitter indicates a current of 0 mA:	Check the wiring for an open circuit. An open circuit is the most common issue with a 0 mA signal.
Transmitter jumps to a current reading between 19 and 20 mA:	Check the installation of the transmitter. Bad installation fittings will cause false signals near the top of the tank, which typically translates to a signal between 19 and 20 mA. Also look for interference just below the transmitter. If the transmitter is installed in a metal fitting, switch to a plastic fitting.
Transmitter indicates a current over 23 mA:	Immediately check the wiring for a short circuit. The EchoSpan® is current limited to 22 mA. Anything above 23 mA indicates a short circuit.

WARRANTY

Flowline warrants to the original purchaser of its products that such products will be free from defects in material and workmanship under normal use and service in accordance with instructions furnished by Flowline for a period of two years from the date of manufacture of such products. Flowline's obligation under this warranty is solely and exclusively limited to the repair or replacement, at Flowline's option, of the products or components, which Flowline's examination determines to its satisfaction to be defective in material or workmanship within the warranty period. Flowline must be notified pursuant to the instructions below of any claim under this warranty within thirty (30) days of any claimed lack of conformity of the product. Any product repaired under this warranty will be warranted only for the remainder of the original warranty period. Any product provided as a replacement under this warranty will be warranted for the full two years from the date of manufacture.

RETURNS

Products cannot be returned to Flowline without Flowline's prior authorization. To return a product that is thought to be defective, go to www.flowline.com, and submit a customer return (MRA) request form and follow the instructions therein. All warranty and non-warranty product returns to Flowline must be shipped prepaid and insured. Flowline will not be responsible for any products lost or damaged in shipment.

LIMITATIONS

This warranty does not apply to products which: 1) are beyond the warranty period or are products for which the original purchaser does not follow the warranty procedures outlined above; 2) have been subjected to electrical, mechanical or chemical damage due to improper, accidental or negligent use; 3) have been modified or altered; 4) anyone other than service personnel authorized by Flowline have attempted to repair; 5) have been involved in accidents or natural disasters; or 6) are damaged during return shipment to Flowline. Flowline reserves the right to unilaterally waive this warranty and dispose of any product returned to Flowline where: 1) there is evidence of a potentially hazardous material present with the product; or 2) the product has remained unclaimed at Flowline for more than 30 days after Flowline has dutifully requested disposition. This warranty contains the sole express warranty made by Flowline in connection with its products. **ALL IMPLIED WARRANTIES, INCLUDING WITHOUT LIMITATION, THE WARRANTIES OF MERCHANTABILITY AND FITNESS FOR A PARTICULAR PURPOSE, ARE EXPRESSLY DISCLAIMED.** The remedies of repair or replacement as stated above are the exclusive remedies for the breach of this warranty. **IN NO EVENT SHALL FLOWLINE BE LIABLE FOR ANY INCIDENTAL OR CONSEQUENTIAL DAMAGES OF ANY KIND INCLUDING PERSONAL OR REAL PROPERTY OR FOR INJURY TO ANY PERSON. THIS WARRANTY CONSTITUTES THE FINAL, COMPLETE AND EXCLUSIVE STATEMENT OF WARRANTY TERMS AND NO PERSON IS AUTHORIZED TO MAKE ANY OTHER WARRANTIES OR REPRESENTATIONS ON BEHALF OF FLOWLINE.** This warranty will be interpreted pursuant to the laws of the State of California. If any portion of this warranty is held to be invalid or unenforceable for any reason, such finding will not invalidate any other provision of this warranty.

For complete product documentation, video training, and technical support, go to www.flowline.com. For phone support, call 562-598-3015 from 8am to 5pm PST, Mon - Fri. (Please make sure you have the Part and Serial number available.)